



AXR.FDCTSQ.12

Refrigerated Food Display Countertop - Square

Product Information:

- Specifically designed to display and store ready-to-serve cold food
- Adjustable digital temperature control (from 2°C - 5°C)
- Efficient LED lighting on each shelf for increased product visibility
- Frameless glass construction (fully double glazed heated) for exceptional display
- Sliding double-glazed glass doors to rear
- Protective coating on refrigeration coil to help prevent corrosion
- 2 Tier Glass Shelving



Designed and Engineered in Australia to meet Australian Standards
24 Months on-site parts and labour warranty

Specifications

Model	AXR.FDCTSQ.12
W x D x H (mm)	1224 x 565 x 676
Weight	113kg
Packed Dimensions (mm)	1300 x 637 x 840
Packed Weight	144kg
Operation	2°C - 5°C
Refrigerant	R290
Climate Class	4M1
Max Ambient	32°C
Power	230VAC / 50Hz / 0.4kW 10A plug & lead

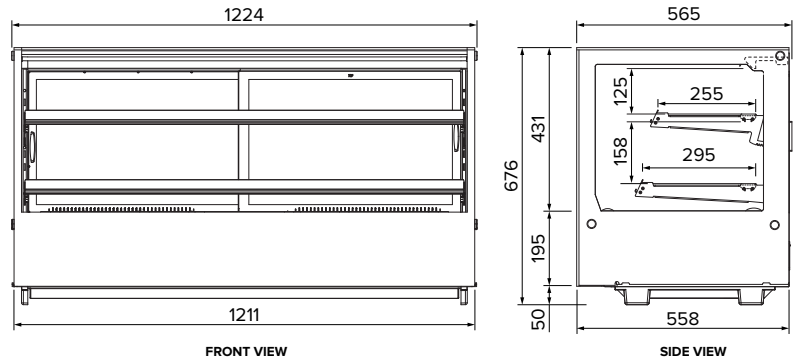

Due to continuous product research and development,
the information contained herein is subject to change without notice.

Revision: F - 01/07/2024 - 02

www.stoddart.com.au
www.stoddart.co.nz

