

specifications

TME1500N-A Series

ActiveCore Series, 3 Door (Glass), Upright Fridge

Project: _____

Item No: _____

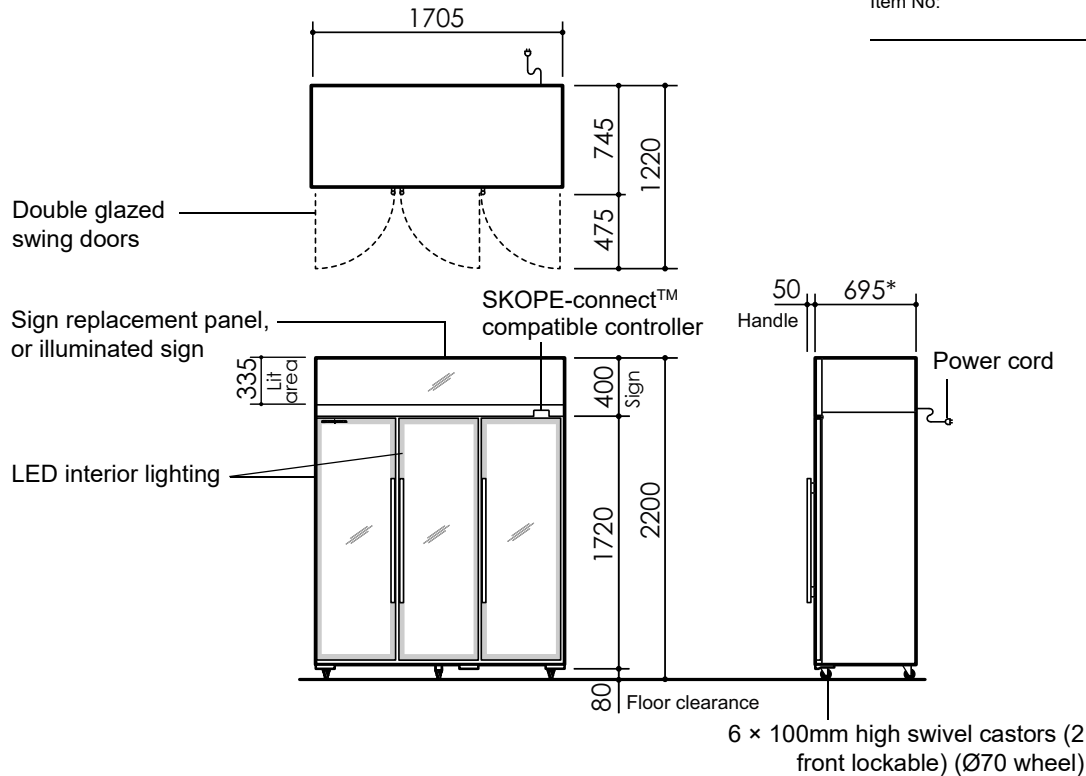

CABINET	
Model ID	TME1500N-A TME1500N-AC
Doors	3 x self-closing, double glazed, single Low-E, argon filled, lockable, argon filled, toughened safety glass swing doors (hinged LH, RH, RH)
Internal door opening	3 x door openings: 1570mm high x 450mm wide
Shelves	15 x adjustable height wire shelves: 500 wide x 470 deep (5 each side), 570 wide x 470 deep (5 middle)
Sign	Sign replacement panel Illuminated sign
Material	Powdercoat galvanized steel
PERFORMANCE	
Max. ambient temp.	40°C
Temperature range	1°C to 4°C (adjustable via SKOPE-connect 1°C to 15°C)
GEMS class	M1 M1
GEMS energy consumption	6.10 kWh/24h 6.28 kWh/24h
GEMS annual running cost	\$668 p.a. (@ \$0.30/kWh) \$688 p.a. (@ \$0.30/kWh)
ELECTRICAL	
Electrical safety climate class	5
Interior side lighting	3 x 1400mm, 15W LED 3 x 1400mm, 15W LED
Sign lighting	n.a. 1 x 1590mm, 18W LED
Power cord	Supplied with 2.3m, 10 Amp plug and lead
Power supply	220-240 Volts a.c. 50 Hz, single phase supply
Current draw	3.4 Amps (includes unit 2.6 Amps)
REFRIGERATION	
Controller	SCS Connect (SKOPE-connect™ compatible)
Connectivity interface	Bluetooth
Refrigeration system	Top mounted, integral, removable ActiveCore refrigeration unit (UTHCNI-0010)
Refrigerant	R290 / 99g (natural refrigerant)
Nominal capacity	740 Watts
Heat rejection (Avg/peak)	265 Watts/350 Watts
Drainage	No plumbing required

DIMENSIONS		
	External	Internal
Height	2200mm	1570mm
Width	1705mm	1605mm
Depth	745mm	554mm
Floor area	1.27m ²	
Weight	320kg	
Gross volume	1497 L	

* Depth 695mm excludes removable door handle and door lock bracket

Dimensional tolerances		
Before installing this cabinet allow the following dimensional tolerances:		
Linear dimensions	Overall cabinet dimensions	
Less than 1 metre	±5mm	
More than 1 metre	-5mm to +10mm	
	Length of multiple cabinets	
	At each joint	At each end wall
Less than 1 metre	±5mm	+15mm
More than 1 metre	-5mm to +10mm	+15mm

Ventilation requirements	
Top	300mm
Sides	Not required
Back	Not required
Bottom	Not required

SKOPE Industries Limited reserve the right to alter specifications without notice. Copyright © 2019 SKOPE Industries Limited

PSS0519 Rev. 1.21 Jul. 2020

SKOPE INDUSTRIES LIMITED

Australian Freephone: 1800 121 535, New Zealand Freephone: 0800 947 5673

Email: skope@skope.com, Website: www.skope.com

