

# specifications

## SK2000-2

SKOPE Three Door Vertical Chiller  
Type: V20BV (LED Lighting)



Two separate top mounted SKOPE Cyclone units

Double glazed swing doors

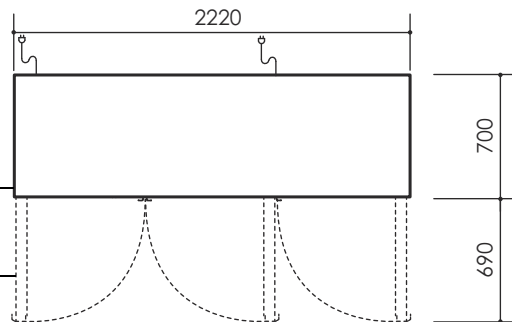

### CABINET DIMENSIONS

	External	Internal
<b>Height:</b>	2195mm	1555mm
<b>adjustable:</b>	2215 to 2230*	
<b>Width:</b>	2220mm	2070mm
<b>Depth:</b>	700mm	520mm
<b>Floor area:</b>	1.55m <sup>2</sup>	
<b>Insulation:</b>	75mm polyurethane foam	

\*Height with optional adjustable castors

Illuminated curved sign panel

2 × Carel ir33 electronic controllers

LED pillar & side lights

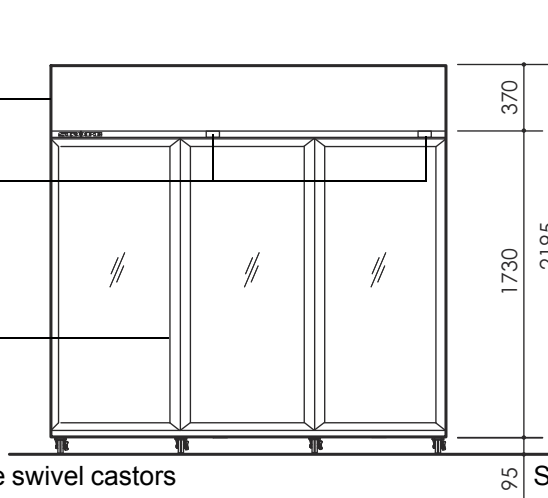

4 × front lockable swivel castors

95 Standard castor height

700

2 × Flexible power cords

4 × Rear swivel castors

Copyright © 2013 SKOPE Industries Limited

### CABINET SPECIFICATIONS

<b>Refrigeration system:</b>	2 × top mounted SKOPE Cyclone refrigeration units (UT43AMD)
<b>Electronic Controller:</b>	CAREL ir33 electronic controller
<b>Refrigerant:</b>	R134a / 530 g (×2)
<b>Nominal capacity:</b>	1720 Watts (2 × 860 Watts)
<b>Cabinet internal volume:</b>	1825 litres
<b>Cabinet temperature range:</b>	+1°C to +4°C up to 43°C ambient
<b>Drainage:</b>	No plumbing required
<b>Electrical:</b>	220-240 Volts a.c. 50 Hz, single phase supply, total 8.8 Amps (2 × 10A plugs)
<b>Internal lighting:</b>	4 × interior lights: 2 × pillar lights 25 Watt T8 twin LED tube (Ø26 × 1500mm) and 2 × side lights 22 Watt T8 LED tube (Ø26 × 1500mm)
<b>Sign lighting:</b>	3 × sign lights: 11 Watt T8 LED tube (Ø26 × 600mm)
<b>Internal door opening size:</b>	3 × door openings: 2 × outside doors 1556mm high × 620mm wide and 1 × inside door 1556mm high × 650mm wide
<b>Doors:</b>	3 × self-closing, double glazed, toughened safety glass swing door
<b>Shelves:</b>	15 × adjustable height wire shelves: 10 × outside shelves 652mm wide × 425mm deep and 5 × inside shelves 725mm wide × 425mm deep
<b>Total weight:</b>	360 kg

SKOPE Industries Limited reserve the right to alter specifications without notice.

PSS0350 Rev. 1.1 Sep. 2013



**SKOPE INDUSTRIES LIMITED**



New Zealand Freephone: 0800 947 5673, Fax: (03) 983 3896. Australian Freephone: 1800 121 535, Freefax: 1800 121 533

Email: enquiry@skope.co.nz Website: www.skope.co.nz